

Description

The Z-300TJ is a small in-line filter designed to expedite the service delivery and improve the performance of digital subscriber line (DSL) services. This model filters all telephone sets, facsimile machines, answering machines, etc. individually or in groups. It also provides a second convenience jack that is unfiltered for connecting DSL. This in-line DSL filter design electronically isolates the high-speed DSL data streams from the voice band plain old telephone service (POTS) equipment. This design effectively blocks the DSL, and other radio frequencies from 25 kilohertz to 30 Megahertz.



The Z-300TJ provides a DSL convenience jack for connecting a DSL modem

Features

- **Data Protection** - Isolates telephone impedances changes from DSL equipment
- Excellent DSL band attenuation that protects voice band equipment and prevents inter-modulation distortion from degrading data rates
- Compatible with all major DSL standards including ADSL, ADSL2+, VDSL, and VDSL2
- **Voice Protection** - Isolates DSL band frequencies from voice band equipment
- Excellent longitudinal balance
- Compatible with Caller ID, facsimile and metallic loop testing
- RoHS compliant
- Compliant and listed with UL 60950, FCC Part 68
- CE certified

Applications

The Z-300TJ filters are used with other Z-BLOCKER filters distributed throughout the subscribers' premises to isolate all voice band equipment devices such as cordless telephones, answering machines, fax machines, dial-up modems, and television set-top boxes.

The Z-300TJ in-line DSL filter is one of many filters manufactured by Excelsus for subscriber installed digital services within homes, offices, and hotels. Excelsus is the number one selling brand of DSL filters worldwide.

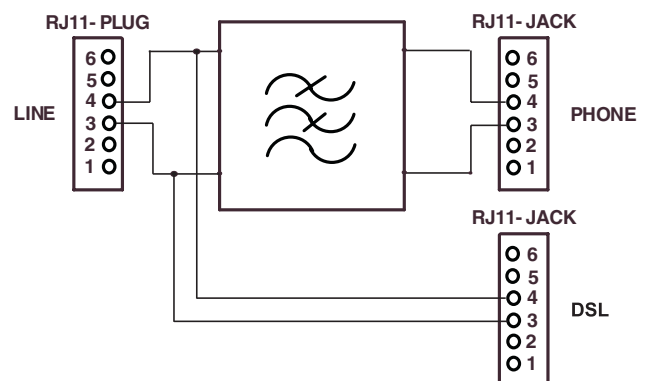

Z-300TJ Block Schematic

Z-BLOCKER Z-300TJ Filter Specifications

Line side differential input blocking impedance		
At 20kHz		>2k
At 30kHz		>3k
From 5MHz to 10MHz		>2k
1kHz insertion loss between 600Ω resistive		
Single filter		<0.4
With 5 filters		<0.6
1kHz/2.8kHz slope between 600Ω resistive		
Single filter		<0.1
With 5 filters		<1.1
DC resistance in Ohms		
Tip to Tip, and Ring to Ring		<12
Tip to Ring		>10M
Longitudinal Balance per IEEE method		
From 200 - 1kHz		>58dB
From 1kHz - 3kHz		>53dB
Common mode rejection, 40kHz and 30MHz		>45dB
Low pass roll off (slope) between 600Ω and ADSL Transmission Unit - Remote		>26dB
Inter-Modulation Distortion First and Second order products		>60dB
Envelope Delay 300 Hz - 2800 Hz		<100μs
600Ω Return Loss into phone side with 600Ω line termination with ATU-R		
Single filter	SRL Low	>30dB
	ERL	>14dB
	SRL High	>17dB
+2 bridged filters	SRL Low	>36dB
	ERL	>23dB
	SRL High	>13dB
+4 bridged filters	SRL Low	>26dB
	ERL	>15dB
	SRL High	>8dB
Complex* Return Loss with ATU-R		
Single filter	SRL Low	>27dB
Single filter	ERL	>14dB
Single filter	SRL High	>6dB
+ 2 bridged filters	SRL Low	>19dB
	ERL	>14dB
	SRL High	>3dB
+ 4 bridged filters	SRL Low	>15dB
	ERL	>7dB
	SRL High	>2dB
*1330Ω in parallel with (100nfd in series with 348Ω)		
DC Loop Current - Meets specifications between 20 and 100 milliamps DC		
Connectors: RJ-11 Jack and RJ-11 Plug.		
RJ11 pins have 50 micro-inches of gold plating		
Dimensions: Length = 53mm, Width = 19.75mm, Height = 18.9mm (Cord length: 75mm)		
Compliant and listed with UL / CSA 60950, FCC CFR 47 Part 68		